

**ARCHITECTURAL
SITE PLAN**

SCALE: 1" = 30'-0"

SITE INFORMATION:

PROPERTY AREA:	3.86 ACRES (168,276 S.F.)
EXISTING ZONING:	RESIDENTIAL ZONE - HIGH DENSITY (RHD)
PROPOSED USE:	MULTI-FAMILY RESIDENTIAL
SETBACKS:	BUILDING: FRONT = 20' SIDE = 10' FOR 3 STORIES REAR = 10'
NUMBER OF UNITS:	72 UNITS (36 - 2 BEDROOM, 36 - 3 BEDROOM)
DENSITY:	18.65 UNITS PER ACRE (MIN. 18 UNITS PER ACRE)
NUMBER OF BUILDINGS:	7
BUILDING AREA:	BLDG 1: 2,633 S.F. BLDG 2-7: 4,865 EACH X 6 = 27,990 S.F. TOTAL BUILDING FOOTPRINTS = 30,623 S.F.
BUILDING COVERAGE:	18.2% (75% MAX)
IMPERVIOUS AREA:	49,970 S.F. (29.7%)
RECREATION AREA:	250 S.F. PER UNIT X 72 = 18,000 S.F. REQUIRED 26,238 S.F. PROVIDED
BUILDING HEIGHT:	39'-11", 3 STORIES (40' MAX)
PARKING REQUIRED:	VEHICLES: 1.0 SPACES PER 2 BEDROOM = 36 SPACES 1.5 SPACES PER 3 BEDROOM = 54 SPACES 90 TOTAL SPACES REQUIRED 90 TOTAL SPACES PROVIDED
	BICYCLES: 1.0 SPACE PER UNIT = 72 SPACES 72 TOTAL SPACES REQUIRED 72 TOTAL SPACES PROVIDED



M+A DESIGN, INC.
24 SOUTH BROOKE STREET
FOND DU LAC, WISCONSIN 54937
l.petrie@madesigninc.net (920) 922-8170



COMMONWEALTH
COMPANIES
9 SHEBOYGAN STREET
FOND DU LAC, WISCONSIN 54935
(920) 922-8170 FAX: (920) 922-8171

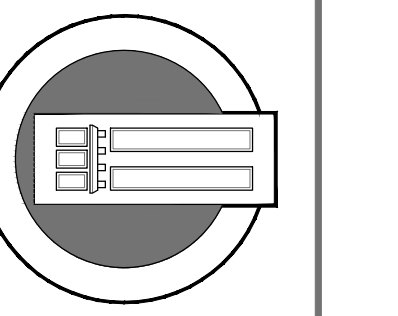

NEW HOUSING PROJECT FOR:
RENAISSANCE FLATS
232 TALENT AVE.
TALENT, OR 97140